

DEPARTMENT OF THE ARMY TECHNICAL MANUAL

**ORGANIZATIONAL, DIRECT SUPPORT, AND GENERAL SUPPORT
MAINTENANCE REPAIR PARTS AND SPECIAL TOOLS LISTS
(INCLUDING DEPOT MAINTENANCE REPAIR PARTS AND SPECIAL TOOLS)**

FOR

**TEST SET, RADIO FREQUENCY POWER AN/URM-182
(NSN 6625-00-148-9371)**

Headquarters, Department of the Army, Washington, D.C.
17 October 1977

Current as of 11 July 1977

REPORTING OF ERRORS

You can help improve this manual by calling attention to errors and by recommending improvements and stating your reasons for the recommendation. Your letter or DA Form 2028 (Recommended Changes to Publication and Blank Forms) should be mailed direct to Commander, US Army Electronics Command. ATTN: DRSEL-MA-Q Fort Monmouth New Jersey 07703. A reply will be furnished direct to you.

Table of Contents

		Page	Figure	Illus
SECTION I.	Introduction	1		
II.	Repair parts list	5		
Group 00	Test Set, Radio Frequency Power AN/URM- 182	5		1
Section III.	Special tools list (Not applicable)			
IV.	National stock number and part number index	6		

* * This manual supersedes* - manual supersedes so much of TM 11-6625-2718-14&P, 30 June 1975, as pertains to repair parts and special tools list.

SECTION I INTRODUCTION

1. Scope

This manual lists spares and repair parts; special tools: special test, measurement, and diagnostic equipment (TMDE), and other special support equipment required for performance of organizational, direct support, and general support maintenance of the AN/URM-182. It authorizes the requisitioning and issue of spares and repair parts as indicated by the source and maintenance codes.

2. General

This Repair Part and Special Tools List is divided into the following sections:

a. Section II. Repair Parts List. A list of spares and repair parts authorized for use in the performance of maintenance. The list also includes parts which must be removed for replacement of the authorized parts. Parts lists are composed of functional groups in numeric sequence, with the parts in each group listed in figure and item number sequence.

b. Section III. Special Tools List. Not applicable.

c. Section IV. National Stock number and Part Number Index. A list, in National item identification number (NSN) sequence, of all National stock numbers (NSN) appearing in the listings, followed by a list, in alphanumeric sequence, of all part numbers appearing in the listings. National stock numbers and part numbers are cross-referenced to each illustration figure and item number appearance.

3. Explanation of Columns

a. Illustration. This column is divided as follows:

(1) *Figure number.* Indicates the figure number of the illustration on which the item is shown.

(2) *Item number.* The number used to identify item called out in the illustration.

b. Source, Maintenance, and Recoverability (SMR) Codes.

(1) *Source code.* Source codes indicate the manner of acquiring support items for maintenance, repair, or overhaul of end items. Source codes are entered in the first and second positions of the Uniform SMR Code format as follows:

Code *Definition*

PA - Item procured and stocked for anticipated or known usage.

XD - A support item that is not stocked. When

Code

Definition

required, item will be procured through normal supply channels.

NOTE

Cannibalization or salvage may be used as a source of supply for any items source coded above except those coded XA and aircraft support items as restricted by AR 700-42

(2) *Maintenance code.* Maintenance codes are assigned to indicate the levels of maintenance authorized to USE and REPAIR support items. The maintenance codes are entered in the third and fourth positions of the Uniform SMR Code format as follows:

(a) The maintenance code entered in the third position will indicate the lowest maintenance level authorized to remove, replace, and use the support item. The maintenance code entered in the third position will indicate one of the following levels of maintenance:

Code *Application/Explanation*

O - Support item is removed, replaced, used at the organizational level.

F - Support item is removed, replaced, used at the direct support level.

H - Support item is removed, replaced, used at the general support level.

(b) The maintenance code entered in the fourth position indicates whether the item is to be repaired and identifies the lowest maintenance level with the capability to perform complete repair (i.e., all authorized maintenance functions). This position will contain one of the following maintenance codes:

Code *Application/Explanation*

H - The lowest maintenance level capable of complete repair of the support item is the general support level.

Z - Nonreparable No repair is authorized.

(3) *Recoverability code.* Recoverability codes are assigned to support items to indicate the disposition action on unserviceable items. The recoverability code is entered in the fifth position of the Uniform SMR Code format as follows:

Recoverability

codes *Definition*

Z - Nonreparable item. When unserviceable, condemn and dispose at the level indicated in position 3.

H - Repairable item. When uneconomically repairable, condemn and dispose at the general support level.

c. National Stock Number. Indicates the National stock number assigned to the item and will be used for requisitioning purposes.

d. Part Number. Indicates the primary number used by the manufacturer (individual, company, firm, corporation, or Government activity), which controls the design and characteristics of the item by means of its engineering drawings, specifications, standards, and inspection requirements to identify an item or range of items.

NOTE

When a stock numbered item is requisitioned, the repair part received may have a different part number than the part being replaced.

e. Federal Supply Code for Manufacturer (FSCM). The FSCM is a 5-digit numeric code listed in SB 708-42 which is used to identify the manufacturer, distributor, or Government agency, etc.

f. Description. Indicates the Federal item name and, if required, a minimum description to identify the item.

g. Unit of Measure (UIM). Indicates the standard of the basic quantity of the listed item as used in performing the actual maintenance function. This measure is expressed by a two-character alphabetical abbreviation (e.g., ea, in, pr, etc). When the unit of measure differs from the unit of issue, the lowest unit of issue that will satisfy the required units of measure will be requisitioned.

h. Quantity Incorporated in Unit. Indicates the quantity of the item used in the breakout shown on the illustration figure, which is prepared for a functional group, subfunctional group, or an assembly.

4. Special Information

The following publication pertains to the AN/URM-182 and its components:

TM 11-6625-2718-14&P, Test Set, Radio Frequency Power AN/URM-182

5. How to Locate Repair Parts

a. When National stock number or part number is unknown.

(1) *First.* Using the table of contents, determine the functional group within which the item belongs. This is necessary since illustrations are prepared for functional groups and listings are divided into the same groups.

(2) *Second.* Find the illustration covering the functional group to which the item belongs.

(3) *Third.* Identify the item on the illustration and note the illustration figure and item number of the item.

(4) *Fourth.* Using the Repair Parts Listing, find the figure and item number noted on the illustration.

b. When National stock number part number is known.

(1) *First.* Using the Index of National Stock Numbers and Part Numbers, find the pertinent National stock number or part number. This index is in NIIN sequence followed by a list of part numbers in alphameric sequence, cross-referenced to the illustration figure number and item number.

(2) *Second.* After finding the figure and item number, locate the figure and item number in the repair parts list.

6. Abbreviations

Not applicable.

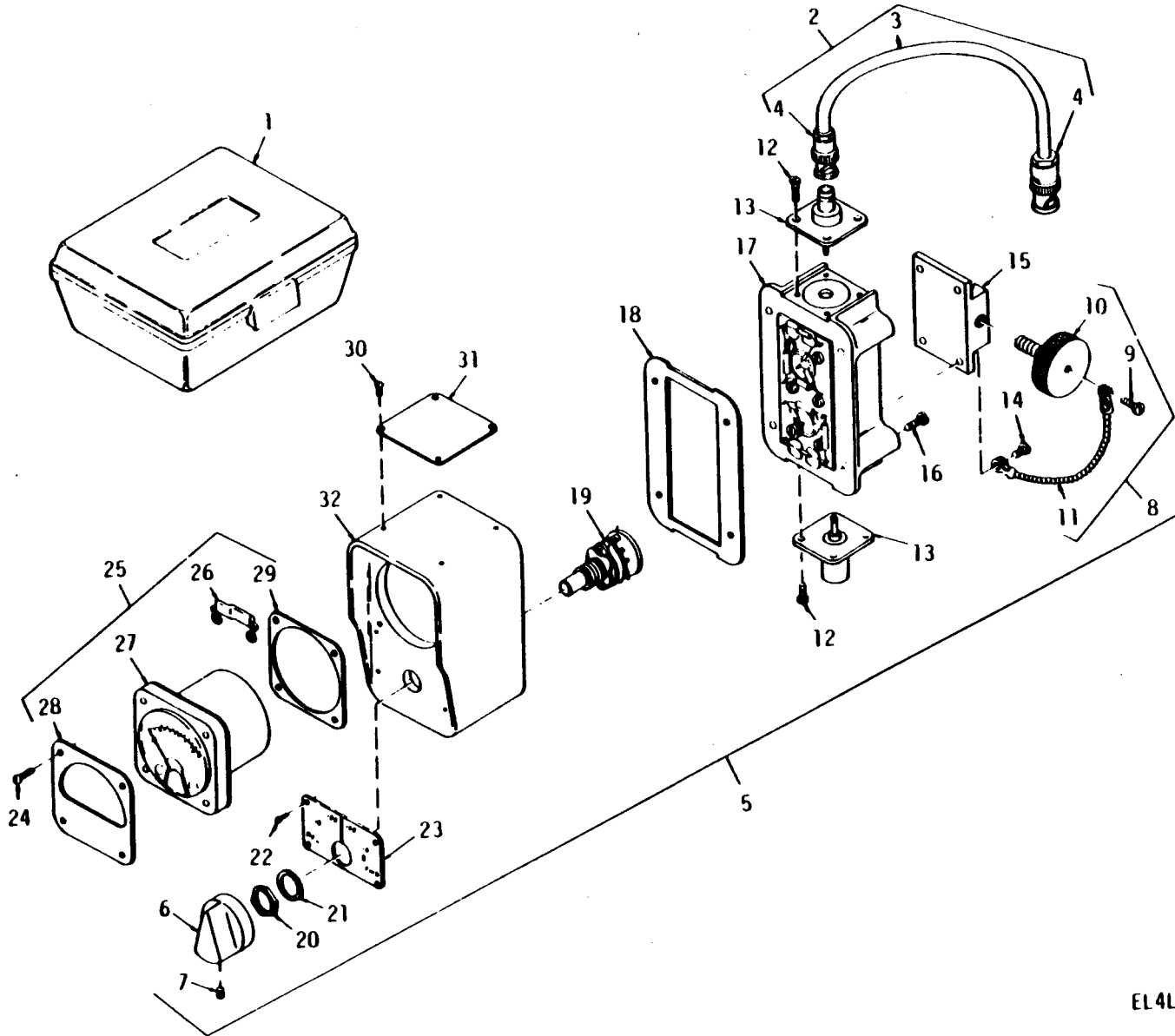

Figure 1. Test Set, Radio Frequency Power AN/URM-182.

EL4L0001

SECTION II (1) ILLUSTRATION		(2)	(3)	(4)	(5)	(6)	(7)	(8)
FIG NO	ITEM NO	SMR CODE	NATIONAL STOCK NUMBER	PART NUMBER	FSCM	DESCRIPTION	USABLE ON CODE U/M	QTY INC IN UNIT
						GROUP 00 TEST SET, RADIO FREQUENCY POWER		
						AM/URM-182		
1	1	PAOZZ	5995-00-503-0470	CY6785U	80058	CASE	EA	1
1	2	PAHHH	5995-00-985-6287	CG409GULFT	80058	CABLE ASSY	EA	1
1	3	PAHZZ	6145-00-542-6092	RG58CU	81349	CABLE	EA	10
1	4	PAHZZ	5935-00-835-0508	UG88GU	81349	CONNECTOR, MALE BNC	EA	2
1	5	PAOHH	6625-01-023-9554	TS2609AU	80058	TEST SET, RADIO FREQUENCY	EA	1
1	6	PAOZZ	5355-00-832-8905	4110-016	70998	KNOB	EA	1
1	7	PAOZZ	5305-00-281-3118	MS51021-32	96906	SETSCREW, CRES	EA	1
1	8	XDHHH		4110-046	70998	SCREW ASSY, CLAMPING	EA	1
1	9	PAOZZ	5305-00-054-6650	MS51957-26	96906	SCREW, MACHINE, RON	EA	1
1	10	XDOZZ		4110-034	70998	THUMBSCREW	EA	1
1	11	XDHZZ		7500-083	70998	CHAIN	EA	1
1	12	PAOZZ	5305-00-054-5647	MS51957-13	96906	SCREW, MAHCINE, BDGW	EA	8
1	13	PAFZZ	5935-00-087-0647	4110-014	70998	CONNECTOR, FEMALE BNC	EA	2
1	14	PAHZZ	5305-00-054-6651	MS51957-27	96906	SCREW, MACHINE, BDGM	EA	4
1	15	XDHZZ		4110-035	70998	BLOCK, CLAMPING	EA	1
1	16	PAHZZ	5305-00-054-6652	MS51957-28	96906	SCREW, MACHINE, FILM	EA	4
1	17	PAHHH	6625-00-995-2303	4110-002	70998	LINE SECTION ASSY	EA	1
1	18	PAHZZ	5330-00-995-2306	4110-057	70998	GASKET, LINE SECTION	EA	1
1	19	PAHHH	5930-00-997-2481	S454	70998	SWITCH ASSY	EA	1
1	20	PAHZZ	5310-00-437-8550	MS25082B20	96906	NUT, HEXAGON	EA	1
1	21	PAHZZ	5310-00-180-0277	MS35333-76	96906	WASHER, LOCK	EA	1
1	22	PAHZZ	5305-00-054-5636	MS51957-2	96906	SCREW, MACHINE, PNH	EA	1
1	23	XDHZZ		4110-036	70998	PLATE, SWITCH	EA	1
1	24	PAHZZ	5305-00-207-7468	MS35214-16	96906	SCREW, MACHINE, PMH	EA	4
1	25	PAHHH	5525-00-995-2299	4110-004	70998	METER ASSEMBLY	EA	1
1	26	PAHZZ	5905-00-010-5387	4110-045	70998	THERMISTOR ASSY	EA	1
1	27	XDHHH		2080-013	70998	METER	EA	1
1	28	XDHZZ		2080-013-1	70998	PLATE, METER	EA	1
1	29	XDHZZ		9808-192416	65029	GASKET, METER	EA	1
1	30	PAHZZ	5305-00-054-5651	MS51957-17	96906	SCREW, MACHINE, PHM	EA	4
1	31	XDHZZ		4110-058	70998	PLATE, IDENTIFICATION	EA	1
1	32	XDHZZ		4110-025	70998	CASE, METER	EA	1

NATIONAL STOCK NUMBER AND PART NUMBER INDEX

STOCK NUMBER	FIGURE NO	ITEM NO	STOCK NUMBER	FIGURE NO	ITEM NO
5905-00-010-5387	1	26	5305-00-207-7468	1	24
5305-00-054-5636	1	22	5305-00-281-3118	1	7
5305-00-054-5647	1	12	6145-00-542-6092	1	3
5305-00-054-5651	1	30	5055-00-832-8905	1	5
5305-00-054-6650	1	9	5935-00-835-0508	1	4
5305-00-054-6651	1	14	6625-00-995-2303	1	17
5305-00-054-6652	1	16	5330-00-995-2306	1	18
5935-00-087-0647	1	13	5930-00-997-2481	1	19
5310-00-180-0277	1	21			

PART NUMBER	FSCM	FIGURE NO	ITEM NO	PART NUMBER	FSCM	FIGURE NO	ITEM NO
CG-409GUILT	80058	1	2	2080-013-1	70998	1	28
CY6785U	80058	1	1	4110-002	70998	1	17
MS25082B20	96906	1	20	4110-004	70998	1	25
MS35214-16	96906	1	24	4110-016	70998	1	6
MS35333-76	96906	1	21	4110-025	70998	1	32
MS51021-32	96906	1	7	4110-034	70998	1	10
MS51957-13	96906	1	12	4110-035	70998	1	15
MS51957-17	96906	1	30	4110-036	70998	1	23
MS51957-2	96906	1	22	4110-045	70998	1	26
MS51957-26	96906	1	9	4110-046	70998	1	8
MS51957-27	96906	1	14	4110-057	70998	1	18
MS51957-28	96906	1	16	4110-058	70998	1	31
RG58CU	81349	1	3	7500-083	70998	1	11
TS2609AU	80058	1	5	9808-192416	65029	1	29
2080-013	70998	1	27				

LATEST PART NUMBER ASSIGNMENTS

PART NUMBER	FSCM	FIGURE NO	ITEM NO
UG88GU	81349	1	4
4110-041	70998	1	13
5454	70998	1	19

LATEST NATIONAL STOCK NUMBER ASSIGNMENTS

STOCK NUMBER	FIGURE NO	ITEM NO
5310-00-437-8550	1	20
5995-00-503-0470	1	1
5995-00-985-8287	1	2
6625-00-995-2299	1	25
6625-01-023-9554	1	5

By Order of the Secretary of the Army:

BERNARD W. ROGERS
General, United States Army
Chief of Staff

Official:

J. C. PENNINGTON
Brigadier General, United States Army
The Adjutant General

Distribution:

Active Army:

USASA (2)
COE (1)
TSG (1)
USAARENBD (1)
DARCOM (1)
TRADOC (2)
Os Maj Cmd (4)
TECOM (2)
USACC (4)
MDW (1)
Armies (2)
Corps (2)
HISA (Ft Monmouth) (33)
Svc Colleges (1)
USASIGS (5)
USAADS (2)
USAFAS (2)
USAARMS (2)
USAIS (2)
USAES (2)
USAICS (3)
MAAG (1)

USARMIS (1)
USAERDAA (1)
USAERDAW (1)
Ft Gordon (10)
Ft Huachuca (10)
Ft Carson (5)
Ft Richardson (ECOM Ofc) (2)
Army Dep (1) except
LBAD (14)
SAAD (30)
TOAD (14)
SHAD (3)
Ft Gillem (10)
USA Dep (2)
Sig Sec USA Dep (2)
Sig Dep (2)
Sig FLDMS (Less Europe) (1)
Units org under fol TOE:
(1 copy each unit)
11-500(AA-AC)
29-134
29-136

NG: None

USAR: None

For explanation of abbreviations used, see AR 310-50.

